

SINGLE CHANNEL LOOP DETECTOR



Application

Loop detectors are used wherever vehicles have to be detected. Like monitoring and safe guarding access ways to counting vehicles. The output signal can be used for controlling door and gate drive mechanisms, operating barriers, controlling traffic light systems in car parks or activating card dispensers in car parks.

The principle is based on a change in the inductance within the loop which is caused by the metallic components of passing vehicles. The changes are picked up and evaluated by a microprocessor.

Technical Specifications

Model	F-LP1
Type	Single channel
Supply Voltage AC	220V, 110V, 24V, 12V
Supply Voltage DC	24V, 12V
Frequency Range	20Khz ~ 170Khz
Reaction time	100ms
Sensitivity	Adjustable in 3 increments (high .medium. low)
Loop Inductance	Ideal 100µH ~ 300µH, Max 50µH ~ 500µH (including connection wiring)
Loop Conn. Wiring	Max 200m, twisted at least 20 times/meter,
Loop connection	<5m optimal
Operating Temperature	-20°C~+65°C
Storage Temperature	-40°C~+85°C
Relative Humidity	≤95%
Dimensions	35Lx74Wx85Hmmm
Weight	300g

Connection Diagram

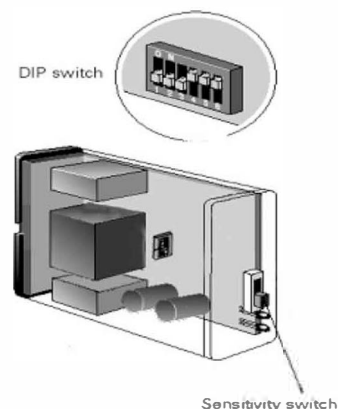
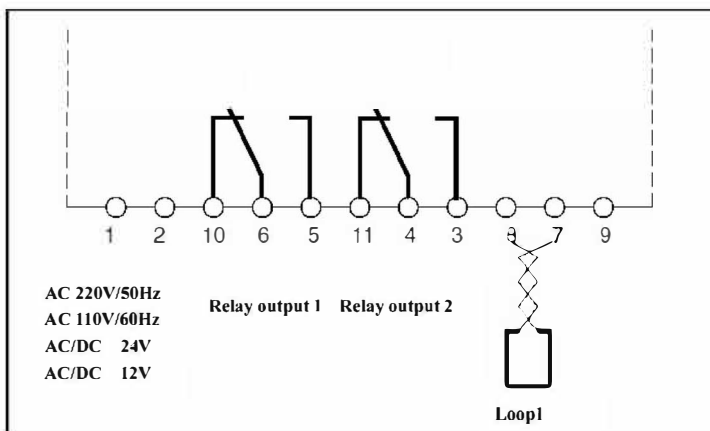

Frequency

The frequency can be altered by means of DIP6-Switch.

- to eliminate interference of two neighboring wire loops
- to eliminate interference of two neighboring loop detectors
- to eliminate interference of two neighboring distribution cables (loop detectors)

Attention: When using more than 2 Detectors, select different frequencies and the screened cables for detector or connecting cables widely separated.

Sensitivity

In order to calibrate on site the wire loop to the loop detector, the sensitivity can be adjusted on the front of the housing by means of a three-stage sliding switch.

- High: high sensitivity (e.g. also bicycles can be detected)
- Medium: medium sensitivity (e.g. for automobiles)
- Low: low sensitivity (preferably Lorries will be detected)

Ensure that the loop is NOT activated when making these adjustments.

Functions of the output relays

Relay	Type	DIP Switch setting	Diagram
Output Relay 2	1	DIP3=OFF	When loop is active, output relay 2 is active. When loop is inactive, output relay 2 is inactive.
	2	DIP3=ON	output relay 2 the same with output relay 2, decided by DIP1, DIP2
Output Relay 1	TLD-110A	DIP2=OFF DIP1=OFF	T1=300mS T2=300mS. When loop is active, output relay 1 is active for T1. When loop is inactive, output relay 1 is active for T2.
	TLD-110B	DIP2=OFF DIP1=ON	T1=300mS. When loop is active, output relay 1 is active for T1.
	TLD-110C	DIP2=ON DIP1=OFF	T1=300mS. When loop is active, output relay 1 is active for T1.
	TLD-110D	DIP2=ON DIP1=ON	T1=300mS. When loop is active, output relay 1 is active for T1.

Default and standard functions

Installation

Loop and Feeder Specification:

The loop must consist of insulated wire with a minimum copper cross-sectional area equivalent to 1.5 square millimeters. The feeder should be of the same material but twisted a minimum of 20 twists per meter.

Joints in the loop or feeder are not recommended. Where this is not possible, Joints are to be soldered and terminated in a waterproof joint bow. This is extremely important for reliable detector performance.

Where long loop feeders are used, or feeders are routed together with other electrical wiring, the use of a screened cable is suggested for the feeder. The screen must be earthed at the detector end only.

Sensing Loop Geometry:

Sensing loops should, unless site conditions prohibit, be rectangular in shape and should normally be installed with the longest sides at right angles to the direction of traffic movement. These sides should ideally be 1meter apart.

The length of the loop will be determined by the width of the roadway to be monitored. The loop should reach to within 300mm of each edge of the roadway. In general, loops having a circumference measurement in excess of 10 meters should be installed using 2 turns of wire, while loops of less than 10 meters in circumference should have three or more turns. Loops having a circumference measurement less than 6meters should be have four turns, It is good practice at time of installation to construct adjacent loops with alternate three and four turn windings to escape crosstalk.

Loop Installation

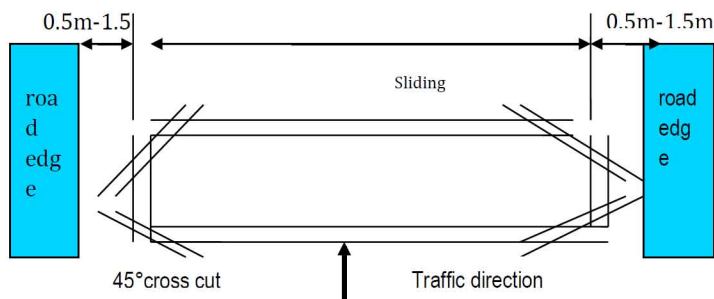

All permanent loop installations should be installed in the roadway by cutting slots with a masonry cutting disc or similar device. A 45° crosscut should be made across the loop corners to reduce the chance of damage that can be caused to the loop cable at right angle corners.

- Nominal Slot width: 4mm.
- Nominal Slot depth: 30mm to 50mm.

A slot must also be cut from the loop circumference at one corner of the loop to the roadway edge to accommodate the feeder.

A continuous loop and feeder is obtained by leaving a tail long enough to reach the detector before inserting the cable into the loop slot. Once the required numbers of turns of wire are will into the slot around the loop circumference, the wire is routed again via the feeder slot to the roadway edge. A similar length is allowed to reach the detector and these two three ends are twisted together to ensure they remain in close proximity to one another (Minimum 20 turns per meter).Maximum recommended loop sensitivity decreases as the feeder length increases, so ideally the feeder cable should be kept as short as possible. The loops are seated using “quick-set” black epoxy compound or hot bitumen mastic to blend with the roadway surface.